



Cook Legacy Intake Design Specifications

Intake Screen Selection Tables

Cook Legacy intake screens are designed to a maximum through screen velocity of 0.5 feet per second.

To determine the screen requirements for your application you need to know the design flow rate and the desired screen opening size. To determine the required screen index divide the design flow rate (in USGPM) by the fractional open area from the table above. The result is the total Screen Index required for your project. Choose a screen with a screen index equal to or greater than the calculated value. Check to ensure that the minimum water depth is at least twice the screen diameter. For large flow rates or shallow waters multiple screens may be required. **Table 1** below is provided to make this process easier. Complete the information on design flow rate, low water level, high water level, and slot size and you are ready to use the sizing tables to select the screen for your project. (Open area can be obtained from **Table 2** and screen capacity / screen index is obtained from **Table 3**.)

A Cook Legacy intake screen is identified by the parameters in the table below. For assistance in screen sizing and selection please contact your **Cook Legacy** representative. If there is no representative in your area call us at (614) 524 4588 or visit www.waterscreen.com

Screen Model Number Definition											
Screen Model											
All dimensions should be in inches	S or T	Screen Diam	Outlet Diam	Slot	Air Burst Size	End Plate or Dished Head	Flange Type AWWA or ANSI	Outlet Flange Matl	Assy Matls	Orientation	No. of deflectors



Cook Legacy Intake Design Specifications

Table 1 Design Information

Table 1 Design Information							
Screen Information							
Design Flow Rate		gpm					
Design Low Water		ft	usually water depth at 100 year low flow				
Design High Water		ft	usually water depth at 100 year flood				
Type of Water Source		River/Stream		Pond/Reservoir/Lake	Open Area		
Slot Size		inches	use 0.080" or 0.125" [3/32" in California] or select from Table 2				
Other Features: Describe							
Calculation of Screen Requirement							
Design Flow Rate _____ / Fractional Open Area (from Table 2) _____ = Screen Index							
Select Screen Model From Table 3 refer to Tables 4 and 5 for screen dimensions							
Verify that there is adequate water depth for the selected screen. Minimum water depth should be at least 2 x the selected screen diameter. Preferred minimum water depth would provide 1 screen diameter clearance above and below the screen assembly							
If water depth is not sufficient use multiple screen assemblies.							
Number of Screen Assys	Screen Model	Outlet Size	Slot Size	Air Burst Pipe size	Material	Outlet Flange Material	No Of Cones
	S or T						

Table 2 Slot and Fractional Open Area (FOA)

Slot	1mm 0.040"	1.5mm 0.060"	2mm 0.080"	3/32"	1/10"	3mm 0.118"	1/8"	5/32"	3/16"	1/4"	3/8"
FOA	0.357	.454	.526	.569	0.585	0.625	0.638	.688	.725	.679	.761

Comments on Screen Model Selection

In many cases either a single screen assembly or a tee assembly can be used to meet the capacity requirements of an application. Factors that would affect your selection include water depth, head loss limitations, and cost.

In general, single screens are less expensive than tee assemblies. There is no mystery in this. Single screens are more efficient and easier to build. There are exceptions to this rule. For example, if the single screen would require splicing and the screen diameter is such that considerable internal reinforcement and the tee assembly would involve screens generated directly from the available tooling the tee assembly might be less expensive. **Cook Legacy** can provide this information very quickly.

Sometimes the available water depth is marginal for the use of a single screen. In such cases we recommend choosing the tee assembly and providing yourself with the extra clearance margin.

There are some situations where head loss through the screen assembly is a critical design factor. Head loss through a tee assembly is in the range of 1/2 to 3/4 feet of water. Head loss through a single screen is about equal to the entrance losses into the intake pipe. Special design arrangements can be provided on tee assemblies to reduce the headloss, particularly if the screen opening size is less than 1/8". **Cook Legacy** would be happy to work with you if head loss is a special concern for your project.

Note: Standard screen sizes are identified for convenience in establishing and selecting the appropriate screen for your project. All intake screens are made to order. Screen assemblies are not stocked. Tooling controls the diameter of the smaller diameter screens. For larger diameters the screen assemblies are spliced to accomplish the desired diameter. If the screen you need seems to fit in a gap in the table please contact us. Cook Legacy would be happy to provide custom sizing information.

The information on the next two pages is provided to provide you with information on the dimensions of a screen that can fulfill your water need. Cook Legacy strives to provide engineered solutions to your unique problem, so we request that in addition to providing us with your estimated model number you explain your situation and water need.

Table 3		
Required Screen Index	Single Screen Model Options	Tee Assembly Model Options
500	S-12	
600	S-14	
700	S-16	
800	S-16	
900	S-18	
1000	S-18	T-12
1200	S-21	T-14
1400	S-21	T-16
1600	S-24	T-16
1800	S-24	T-18
2000	S-27	T-18
2250	S-28	T-21
2500	S-28	T-21
2750	S-30	T-21
3000	S-30	T-21
3500	S-33	T-24
4000	S-36	T-27
5000	S-40	T-28
6000	S-42,S-44	T-30
7000	S-48	T-33
8000	S-54	T-36
9000	S-54	T-36
10000	S-60	T-40
12000	S-60	T-40
14000	S-66	T-48
16000	S-72	T-54
18000	S-78	T-54
20000	S-78,S-84	T-66
25000		T-66
30000		T-72
35000		T-72
40000		T-78
45000		T-84
50000		

Standard Drum Screen Dimensions

Table 4 Single Screen Assembly Model, Screen Index and Dimensions								
Model	Screen Index	Screen Area – sq.in	Diam. in.	Screen Length in	Weight pounds	Outlet In.	Air Burst Size in	Overall length in
S-12	525	481	12 3/4	12	30	6	1	22
S-14	672	616	14	14	35	6	1	24
S-16	877	804	16	16	40	8	1 1/2	26
S-18	1110	1018	18	18	55	8	1 1/2	28
S-21	1512	1386	21	21	85	10	1 1/2	31
S-24	1975	1810	24	24	110	12	2	34
S-27	2498	2290	27	27	150	12	2	37
S-28	2687	2463	28	28	190	14	2	38
S-30	3084	2827	30	30	245	14	3	40
S-33	3732	3421	33	33	340	16	3	43
S-36	4442	4072	36	36	370	18	3	46
S-40	5484	5027	40	40	400	20	3	50
S-42	6046	5542	42	42	425	20	4	55
S-44	6635	6082	44	44	450	20	4	57
S-48	7896	7238	48	48	500	24	4	61
S-54	9994	9161	54	54	625	24	6	73
S-60	12338	11310	60	60	775	30	6	79
S-66	14929	13685	66	66	1050	30	6	85
S-72	17767	16286	72	72	1200	36	8	97
S-78	20852	19114	78	78	1475	36	8	103
S-84	24182	22167	84	84	1700	42	8	109

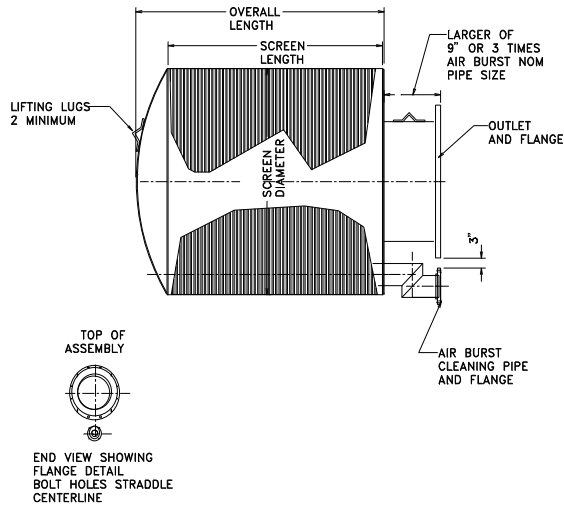

Standard Tee Screen Dimensions

Table 5								
Tee Assembly Model, Screen Index and Dimensions								
Model	Screen Index	Screen Area – sq.in	Diam. in.	Overall Length in	Weight pounds	Outlet In.	Air Burst Size in	CL to Flange Face in
T-12	1050	962	12 3/4	40	100	10	1	12 3/4
T-14	1344	1265	14	44	120	10	1	14
T-16	1754	1608	16	52	135	12	1 1/2	15
T-18	2220	2036	18	56	170	14	1 1/2	16 1/2
T-21	3024	2772	21	66	290	16	1 1/2	18
T-24	3950	3620	24	74	375	18	2	22
T-27	4996	4580	27	82	460	20	2	24
T-28	5374	4926	28	84	500	20	2	25
T-30	6168	5654	30	92	640	24	3	25
T-33	7464	6842	33	97	780	24	3	26
T-36	8884	8144	36	104	1050	30	3	29
T-40	10968	10054	40	118	1150	30	3	32
T-42	12092	11084	42	122	1200	30	4	33
T-44	13270	12164	44	126	1350	30	4	34
T-48	15792	14476	48	140	1600	36	4	36
T-54	19988	18322	54	152	2000	36	6	41
T-60	24676	22620	60	170	2500	42	6	44
T-66	29858	27370	66	188	3700	48	6	48
T-72	35534	32572	72	200	4300	48	8	51
T-78	41704	38228	78	218	5100	54	8	55
T-84	48364	44334	84	236	6000	60	8	59

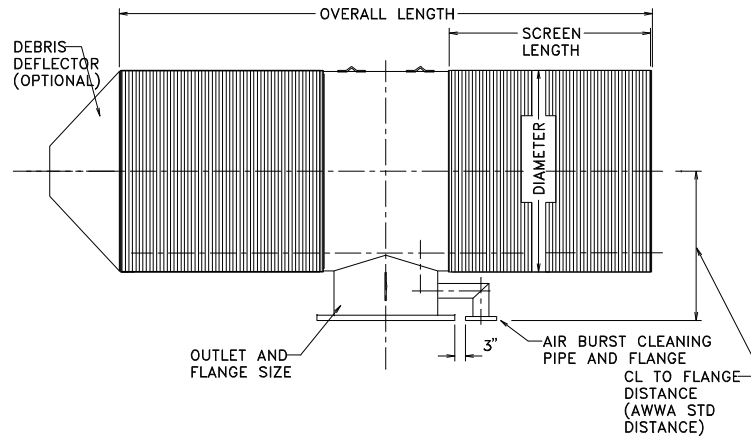

ORIENTATION LOOKING UPSTREAM

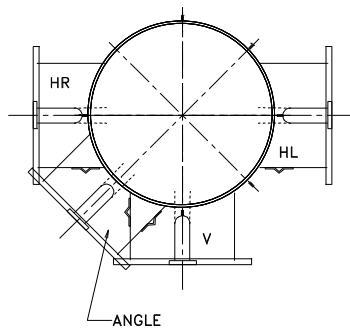

Cook Legacy Intake Screen Specifications

Intake Screen Specification

I. General: The intake screen shall be of all-welded continuous slot construction to provide maximum open area commensurate with the strength requirements identified herein. The slots shall widen inwardly from the screen surface so as to minimize the chance of debris entrapment in the screen openings. The screen includes Cook Legacy Custom Flow Modifier. Screen inflow velocity shall be determined using inviscid flow field modeling and confirmed by physical testing on similar screen model. All welding of the screen assembly shall be performed by ASME certified welders. The screen assembly shall be manufactured by **Cook Legacy Water & Energy**. It may seem unnecessary to require welding by ASME certified welders. This is necessary because your water supply depends upon these welders, and ASME Welders are the best.

1. Screen Index: The screen index shall equal or exceed _____.

2. Capacity: The screen capacity shall be _____ US GPM at a maximum local through slot velocity as a result of water withdrawal not to exceed 0.5 feet per second. At this flow rate the pressure drop through the clean screen surface shall not exceed 0.1 psi. Pressure drop through a single screen assembly shall be in the range of 1/4 foot of water. Pressure drop through a tee assembly shall be in the range of 3/4 feet of water.

Cook Legacy intake screens can be designed to any maximum through screen velocity that your project requires. 0.5 feet per second maximum through screen velocity is a common design velocity. Some states and some Canadian Provinces require use of a different design velocity. Contact us. We would be happy to work with you in defining the specific screen required for your application.

3. Strength: The screen shall withstand a differential hydrostatic collapse pressure in excess of _____ pounds per square foot (625 pounds per square foot is a common design differential).

4. Construction: The surface wire shall be **Cook Legacy** shape number 60 (or 130 when slot is 1/4 inch or greater) or an equivalent cold rolled shape that will provide the same strength and open area. The surface wire, support beam and stiffener structure are an all welded matrix designed to provide the specified strength while providing minimal interference with the through screen flow pattern. End plates, outlet pipe, and tee body are a minimum of 1/4" thick.

Defining all of the forces to which the screen assembly might be exposed can be a very difficult task. Defining a minimum thickness for the key components of the assembly is good practice.

5. Slot: The screen slot opening shall be _____ inches. The open area for this slot opening is _____ %. Slot size shall be controlled and continuously monitored during manufacture.

6. Materials: The screen assembly shall be manufactured of one corrosion resistant metal, _____ stainless steel except the _____" main outlet flange which shall be a stainless steel plate flange to mate with AWWA C207 Table 1 Class D bolt pattern.

7. Submittals: A graph of local through slot velocity indicating maximum, average, and minimum through slot velocity shall be provided along with any other required submittals.

Cook Legacy Water & Energy

Ohio Office: 8120 Howe Industrial Pkwy
Canal Winchester, OH 43110
phone: (614) 524 4588
fax: (614) 524 4586

Atlanta Office: 2795 Greenrock Trail
Atlanta, GA 30340
phone: (770) 414 1861
fax: (770) 414 0605

Web: www.waterscreen.com